

Rose

Flower

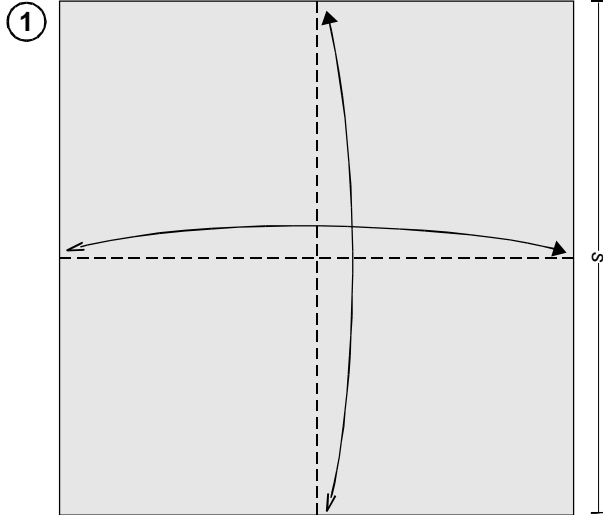

Fold and unfold.

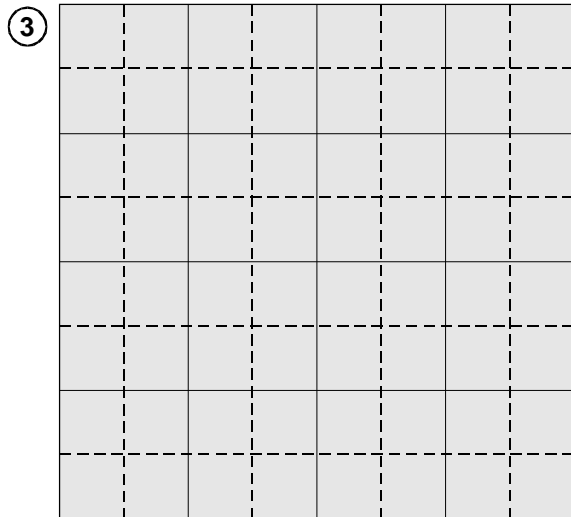

Fold and unfold, creasing lightly.

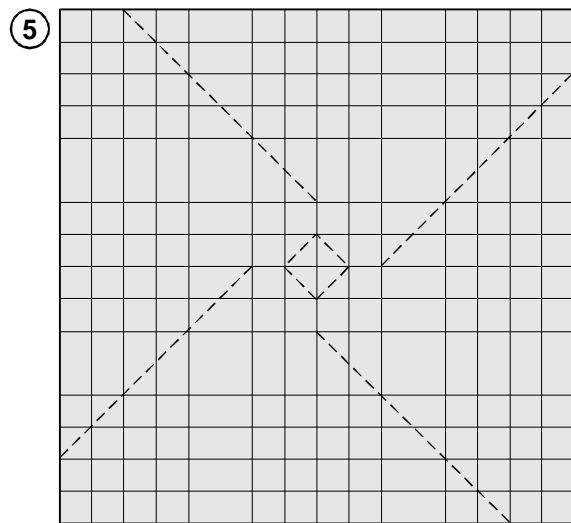

Fold and unfold, then turn over in preparation for the "Kawasaki twist"...



Toshikazu Kawasaki

Diagrams by C.A.Furuti
020902a

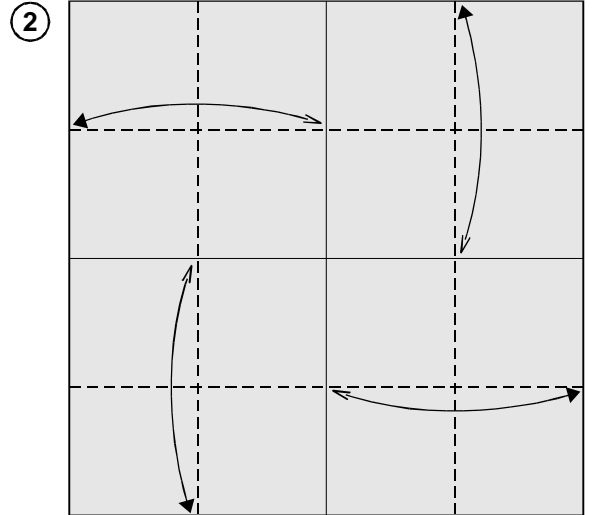

Fold and unfold, crease lightly.

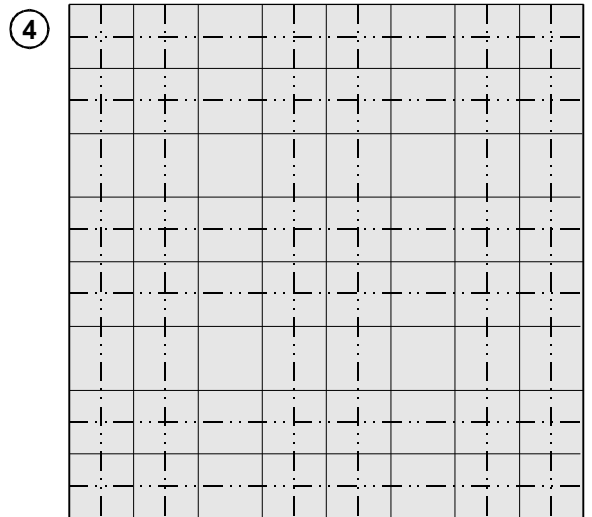

Fold and unfold.

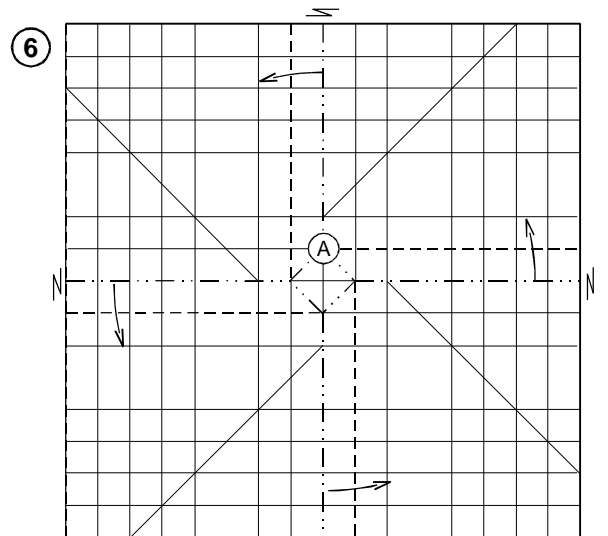

... pinching the long mountain folds, creating four spines. Lift a small square at center, rotate it 1/4 turn then flatten.

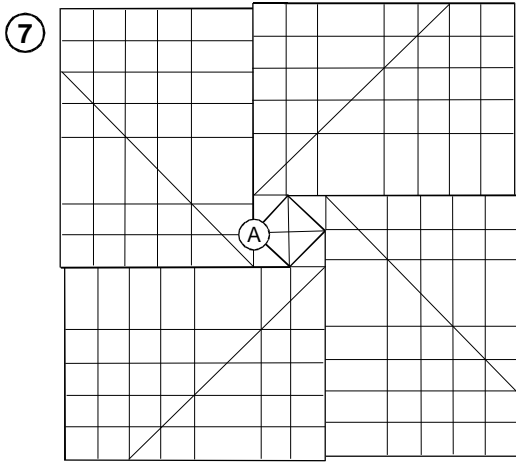

Turn over.

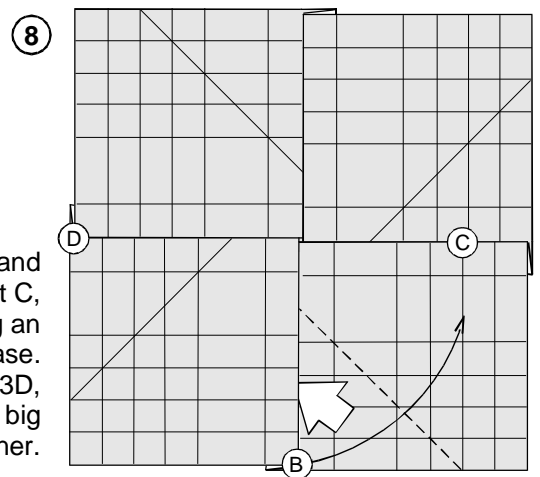

Grab point B and pull it over point C, folding along an existing crease. Model becomes 3D, resembling a big three-sided corner.

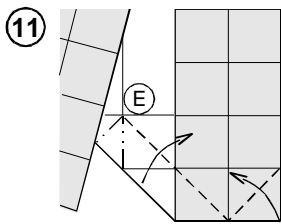

Point E becomes a 3D corner.

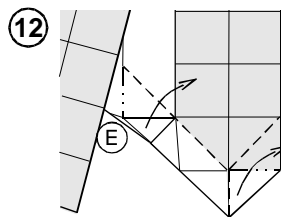

Rabbit-ear on the right; flatten corner E creating another 3D corner.

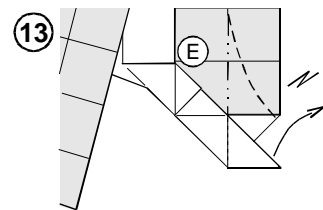

Crimp, curving the colored tip inwards; the valley fold may be adjusted later.

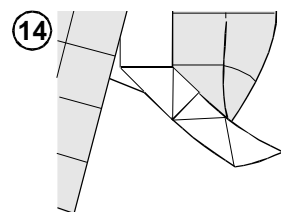

Repeat steps 10 to 13 in other three flaps; interweave the calyx (four white tips).

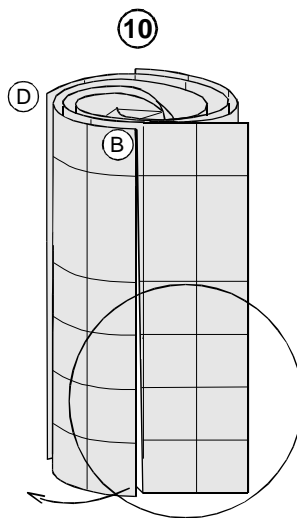

Note the circled area; slightly lift the flap on the left.

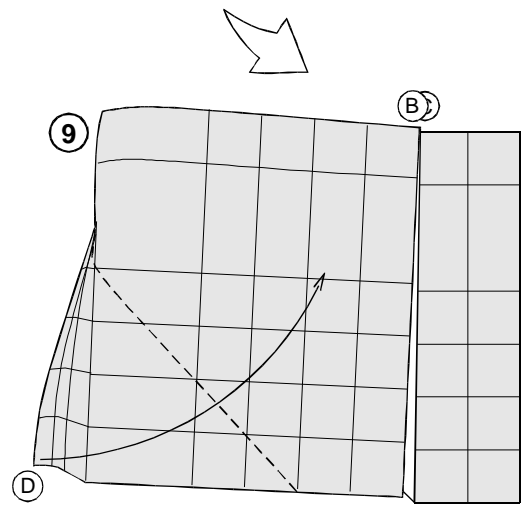

Keeping B and C joined, repeat step 8 on three other flaps, beginning with D. Model now resembles a tube with one end closed.

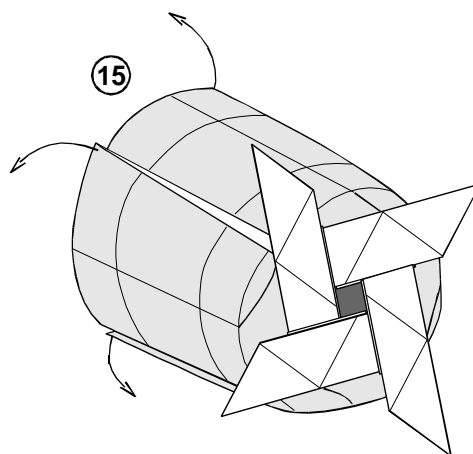

Curl corners of four petals; round bottom and top edges.

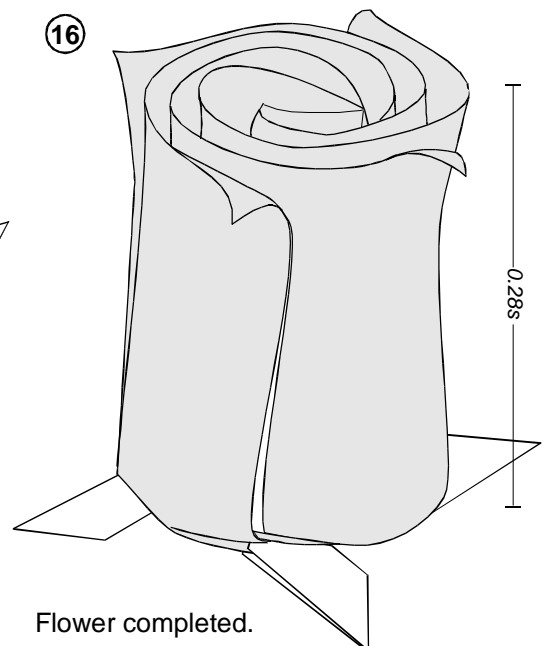

Flower completed.

Stand and Leaves

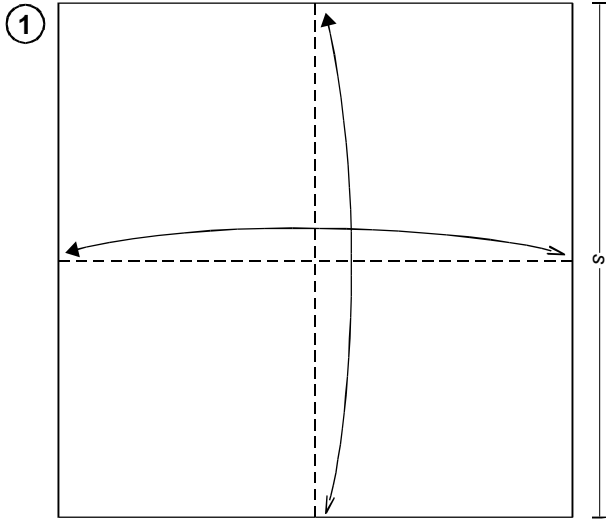

Fold and unfold.

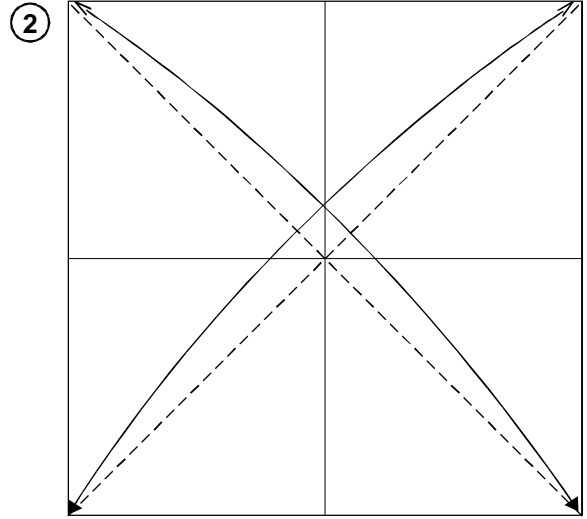

Fold and unfold.

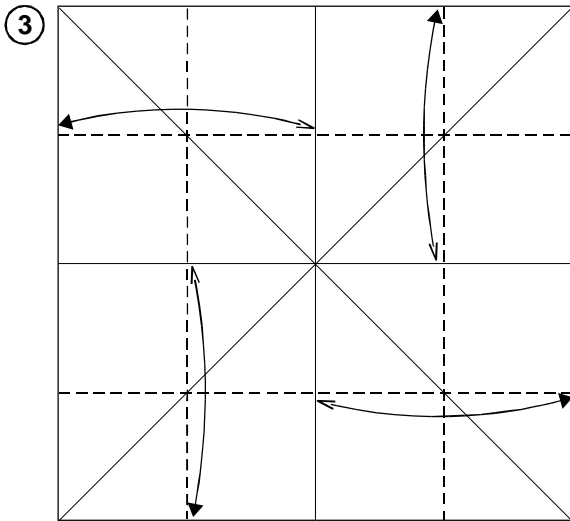

Fold and unfold.

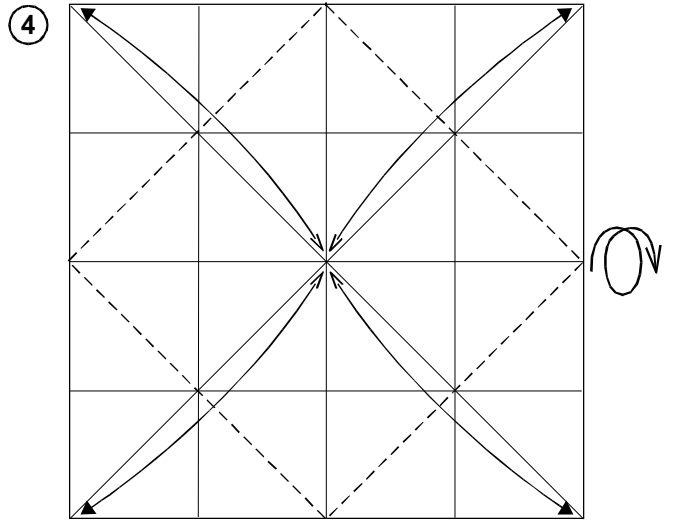

Fold and unfold, then turn over.

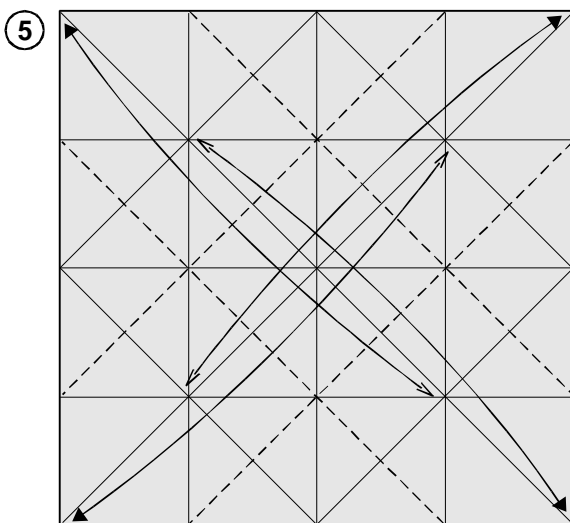

Fold and unfold.

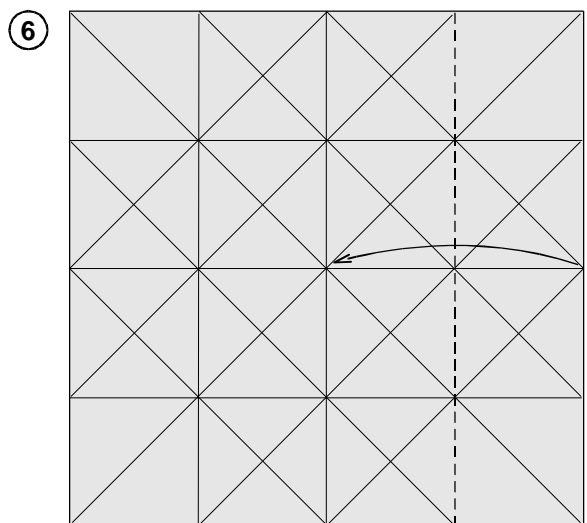

7

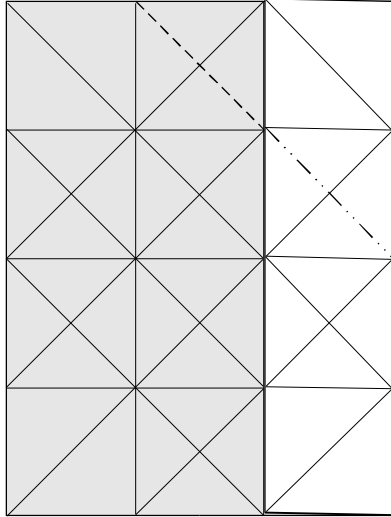

Reverse-fold.

8

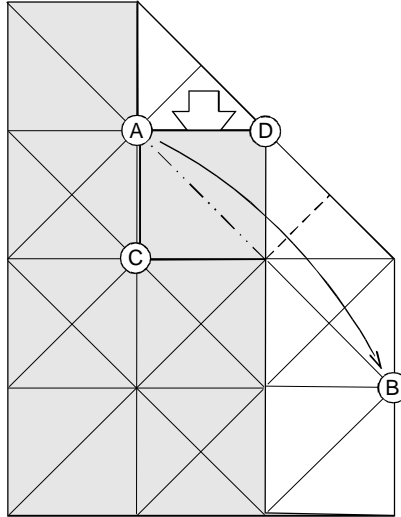

Bring point A to B, also joining C and D; model will not lie flat.

9

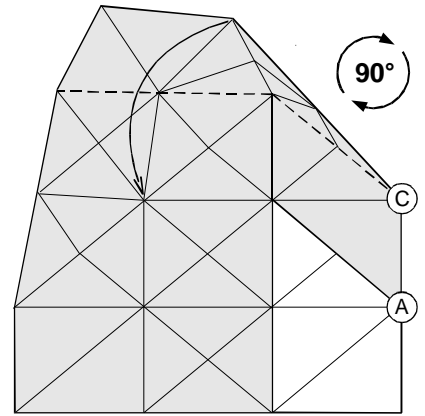

Flatten the model, then rotate 90 degrees.

10

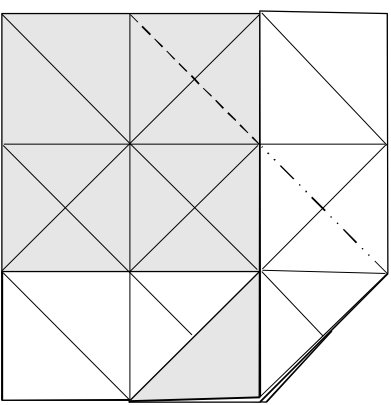

All four corners will be identical at step 13. First repeat steps 7 to 9.

11

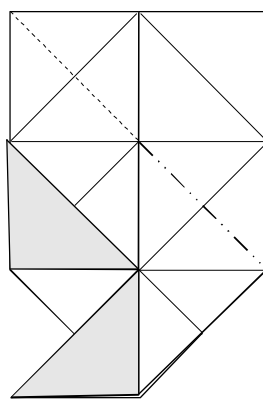

Again, repeat 7 to 9. The x-ray line marks a rabbit-ear.

12

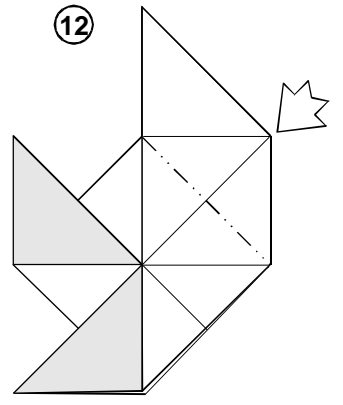

Finally, open sink without disturbing the middle flap.

13

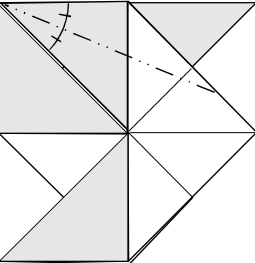

Narrow one layer, bisecting the angle.

14

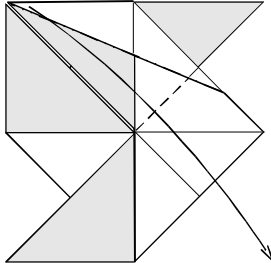

Valley fold, then repeat step 13.

15

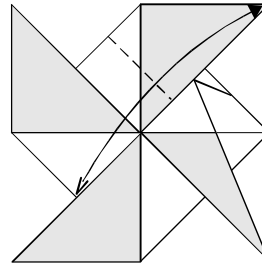

Fold and unfold.

16

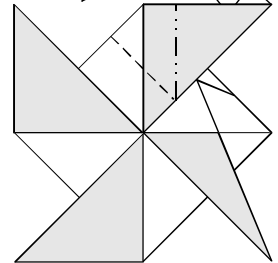

Squash-fold.

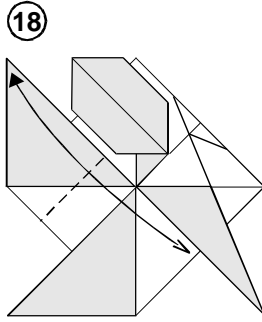
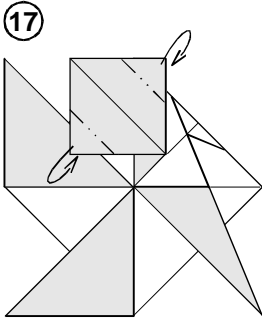

Repeat steps 15 to 17 in other two leaves.

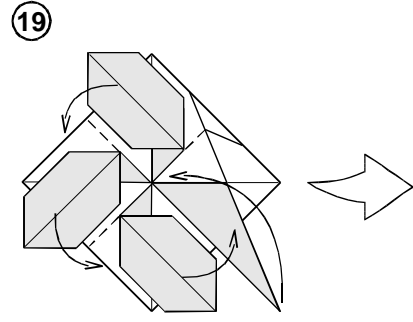

Raise four appendages, keeping the three leaves parallel to the stand.

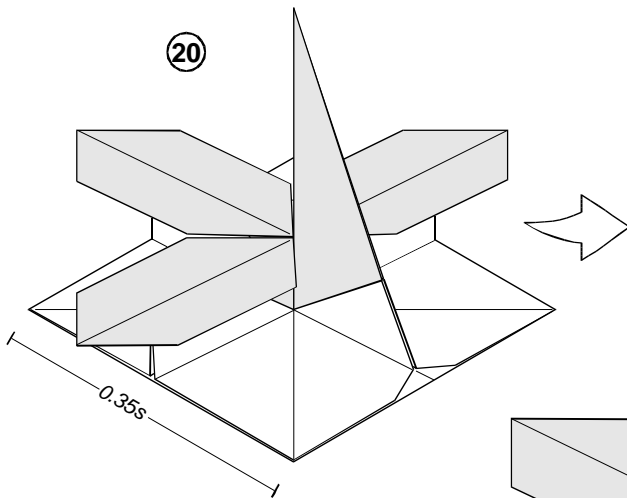

Stand completed.
Insert stalk into flower.

